

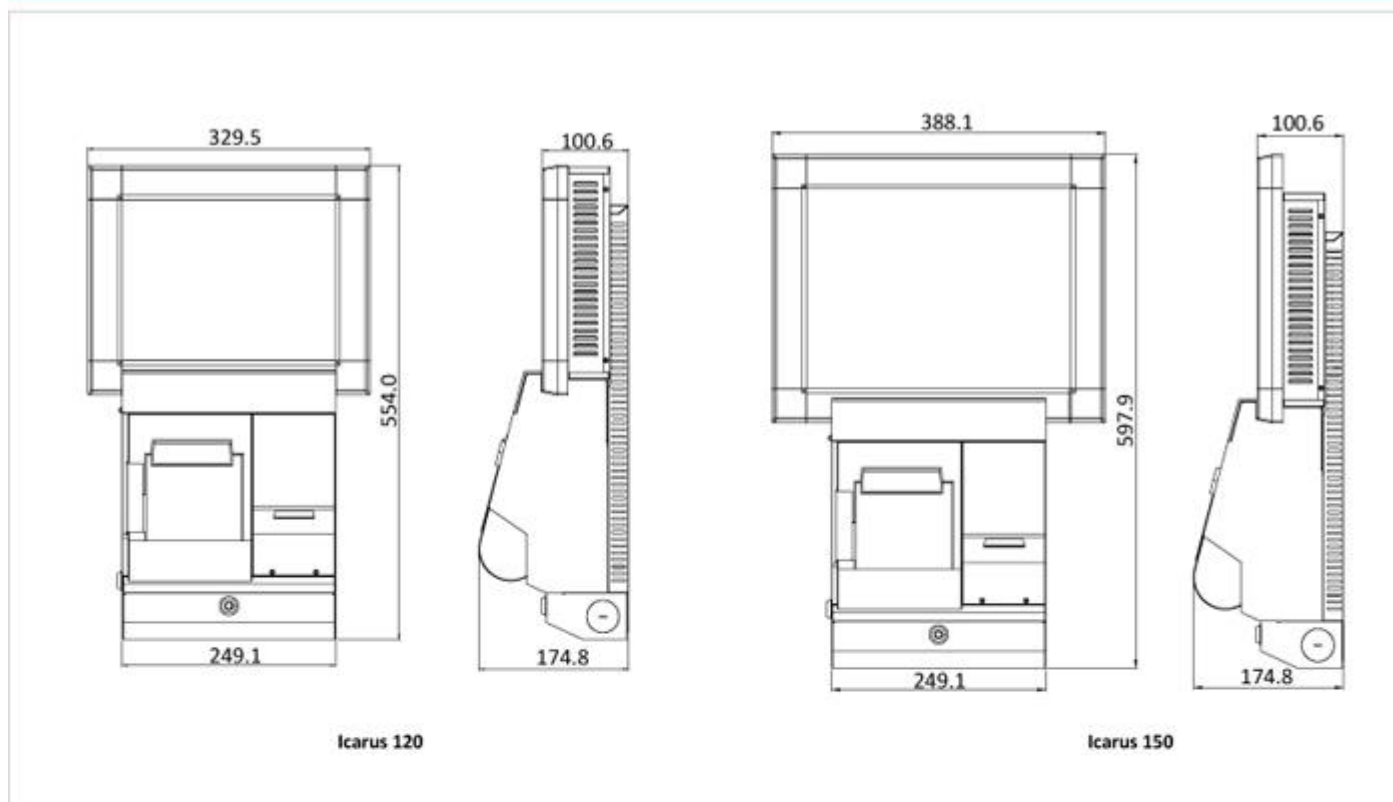

Processor System	CPU FCBGA559 (on Board)	Atom D2550
	Frequency	1.86GHz
	L3 Cache	1 MB
	Main Board	PC25N
	System Chipset	Intel® Cedarview & NM10
	BIOS	AMI 16-Mbit SPI Flash BIOS
Memory	Technology	DDR3 800/1066 MHz
	Max. Capacity	2 GB
	Socket	1 x 204-pin SO DIMM
Internal Display 12"	Panel Size	12.1"
	Resolution	800x600
	Viewing Angle	Right : 80 / Left : 80 / Upper : 65 / Lower : 75 degree
	Brightness	450 cd/m <sup>2</sup>
	Color Support	16.2M/262K Color
	Contrast Ratio	700
	Response Time	35ms (Rising : 25 ms / Falling : 10 ms)
Internal Display 15" (CCFL Backlight)	Panel Size	15.0"
	Resolution	1024x768
	Viewing Angle	Horizontal : 80 / Vertical : 70 degree
	Brightness	250 cd/m <sup>2</sup>
	Color Support	16194277/262144 Color
	Contrast Ratio	700
	Response Time	16ms (Rising : 5 ms / Falling : 11 ms)
External Display	Digital Display	1920 x 1200, Max. data rate up to 1.65 Gb/s
	CRT	Max. resolution up to 1920x1200 true color
Touchscreen 12"	Touchscreen Type	5 Wire Resistive
	Surface Hardness	3H Pencil ,Pressure 1N/45°
	Durability	10000000 times
	Transparency	80% (±5%)
Touchscreen 15"	Touchscreen Type	5 Wire Resistive
	Surface Hardness	3H Pencil ,Pressure 750g/45°
	Durability	10000000 times
	Transparency	80% (±.3%)
I/O Interface	USB	USB 2.0 x 2
	Serial Port	
Ethernet	Speed	10/100/1000 Mbps
	Controller	Realtek RTL8111E-VC-CG
	Connector	RJ45 x 1
Audio	Chipset	Realtek ALC662-GR

	Speaker	Internal : Speaker 8Ω/2W x2
Storage	HDD	Supports one 2.5" SATA HDD
Scanner (Optional)	IS3480 A-52M	1D omni-direction (Optional) CCD-2D (Optional)
Printer (Optional)	NP-K3052D	3" (80mm) Auto Loading Paper near-end detection
	TMT-88	79.5 mm ± 0.5 mm {3.13" ± 0.02"} Unidirectional with friction feed 180 dpi ×180 dpi [dots per 25.4 mm {1"}]
MSR (Optional)	MSR220HK	Reference Standards : ISO 7810 ,7811 Recording Method : Two-frequency coherent phase(F2F) Decoding Method : ISO : Ttrack1-IATA , Track2-ABA , Track3-THRIFT Card Swiping Direction : Bi-Direction
Wifi (Optional)	RTL8188CUS-SC5x	802.11n 1T1R Solution for 2.4G Hz band
Power	Power Type	Adapter 120W/19V FSP120-AAB
	Power Input	DC 19V
	Battery	Lithium 3 V / 220 mAH

## Dimensions



Music Download Kiosk

## Option

